

EDITION / VERSİYON  
UPDATE / GÜNCELLEME

01/2019  
12/2024



# 24Z

## GLASS PARTITION SYSTEM CAM BÖLME SİSTEMİ



**KURTOĞLU®**  
ALUMINIUM





www.kurtogluaz.com



'KURTOĞLU ALÜMİNYUM SİSTEMLERİ,  
MİMARİ PROJELERİNİZE ESTETİK ÇÖZÜMLER SUNAR.'

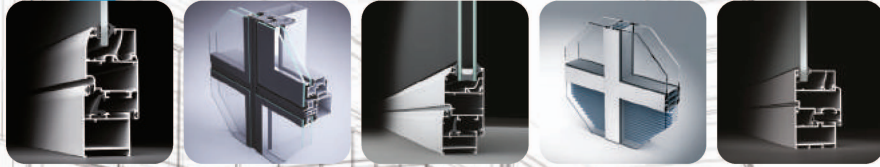

## COMPANY INFORMATION

### FİRMAMIZ HAKKINDA

Our company started its operations with copper and lead casting in the 1960s, and in 1980, we started to serve in the Aluminium Sector with aluminium extrusion press that has 1200 ton capacity. KURTOGLU Aluminium is located in Çorlu, approximately 100 km away from Istanbul and operates in 31.000 m<sup>2</sup> indoor area. With our latest investments, our company has become a modern integrated facility.

- Annual production capacity 34.000 tons,
- Approximately ~500 qualified employees
- ISO 9001:2015 Quality System

- Qualicoat Seaside Certificate
- Qualanod Certificate
- CE Certificate
- EPD Certificate

The main production features of our Company are described as follows:

- Molding Room (Wire Erosion, Treatment Center),
- Aluminium Extrusion Presses, (800 tons, 1460 tons, 1880 tons, 1460/1880 tons, 2100 tons and 2600 tons),
- Anodic Oxidation Facility (75.000 amps - 412.500 m<sup>2</sup> / month)
- Electrostatic Powder Paint Facility (750.000 m<sup>2</sup> / month)
- Mechanical Processing Section (CNC Treatment Center)

Kurtoğlu Aluminium exports its products to; U.S. America, Switzerland, Germany, Austria, Belgium, Sweden, Albania, England, Greece, Bulgaria, Cyprus, Serbia, Bosnia and Herzegovina, Kazakhstan, Montenegro, Hungary, Georgia, Croatia, Turkmenistan, Kyrgyzstan, Azerbaijan, Moldova, Ukraine, Macedonia, Kosovo, Romania, Belarus, Czech Republic, Libya, Iraq, Algeria, Tunisia, Qatar, Nigeria, Israel, Ghana, Gabon, France, India, Saudi Arabia, Burkina Faso, Ethiopia, Egypt, Ivory Coast, Morocco, Poland, The Netherlands, Russia, Madagascar, Niger, Tanzania, Mozambique, Norway, Lebanon, Mayotte, Palestine, Senegal, Somali, Benin, Canada, Panama, Iceland.

KURTOGLU ALUMINIUM continues to operate based on the principle of providing services to its customers with zero fault.

Şirketimiz 1960' lı yıllarda Bakır ve Kurşun ile üretim hayatına başlamıştır. 1980 yılında 1200 tonluk Alüminyum Ekstrüzyon presi ile üretim sektörüne girmiştir.

KURTOGLU Alüminyum; İstanbul'a yaklaşık 100 km mesafede Çorlu'da bulunmakta ve 31.000 m<sup>2</sup> kapalı alanda faaliyetini sürdürmektedir. Son yapılan yatırımlarla şirketimiz modern bir entegre tesis haline ulaşmıştır.

- Yıllık kapasite ~ 34.000 ton
- Yaklaşık ~ 500 kalifiye eleman
- ISO 9001:2015 kalite sistemi

- Qualicoat Seaside Belgesi
- Qualanod Belgesi
- CE Belgesi
- EPD Belgesi

Şirketimizin ana özellikleri aşağıda da belirtilmiştir:

- Kalıphane Bölümü (Tel erozyon, İşleme Merkezi)
- Alüminyum Ekstrüzyon Presleri; ( 800 ton, 1460 ton, 1880 ton, 1460/1880 ton, 2100 ton ve 2600 ton),
- Eloksal Tesisi ( 75.000 Amper - 412.500 m<sup>2</sup> / Ay)
- Elektrostatik Toz Boya Tesisi ( 750.000 m<sup>2</sup> / Ay)
- Mekanik İşlem Bölümü ( CNC İşleme Merkezi )

KURTOĞLU Alüminyum Ürünleri; Amerika, İsviçre, Almanya, Avusturya, Belçika, İsveç, Arnavutluk, İngiltere, Yunanistan, Bulgaristan, Kıbrıs, Sırbistan, Bosna Hersek, Kazakistan, Karadağ, Macaristan, Gürcistan, Hırvatistan, Türkmenistan, Kırgızistan, Azerbaycan, Moldova, Ukrayna, Makedonya, Kosova, Romanya, Beyaz Rusya, Çek Cumhuriyeti, Libya, Irak, Cezayir, Tunus, Katar, Nijerya, İsrail, Gana, Gabon, Fransa, Hindistan, Suudi Arabistan, Burkina Faso, Etiyopya, Mısır, Fil Dişi Sahili, Fas, Polonya, Hollanda, Rusya Federasyonu, Madagaskar, Nijer, Tanzanya, Mozambik, Norveç, Lübnan, Mayotte, Filistin, Senegal, Somali, Benin, Kanada, Panama ve İzlanda'ya ihraç edilmektedir.

KURTOĞLU ALÜMİNYUM müşterilerine sıfır hata ile hizmet vermeyi temel olarak çalışmalarını sürdürmektedir.

# 'The countries of export; İhracat yapılan ülkeler'



## **Kurtoğlu Aluminium countries of export / İhracat yapılan ülkeler.**

- U.S. America / Amerika
- Switzerland / İsviçre
- Germany / Almanya
- Austria / Avusturya
- Belgium / Belçika
- Sweden / İsveç
- Albania / Arnavutluk
- England / İngiltere
- Greece / Yunanistan
- Bulgaria / Bulgaristan
- Cyprus / Kıbrıs
- Serbia / Sırbistan
- Montenegro / Karadag
- Hungary / Macaristan
- Georgia / Gürcistan
- Kazakhstan / Kazakistan
- Croatia / Hırvatistan
- Turkmenistan / Türkmenistan
- Kyrgyzstan / Kırgızistan
- Azerbaijan / Azerbaycan
- Moldova / Moldovya
- Ukraine / Ukrayna
- Macedonia / Makedonya
- Kosovo
- Romania / Romanya
- Belarus / Beyaz Rusya
- Czech Republic / Çek Cumhuriyeti
- Libya / Libya
- Iraq / Irak
- Algeria / Cezair
- Tunisia / Tunus
- Bosnia and Herzegovina / Bosna Hersek
- Qatar / Katar
- Nigeria / Nijerya
- Israel / İsrail
- Ghana / Gana
- Gabon / Gabon
- France / Fransa
- India / Hindistan
- Saudi Arabia / Suudi Arabistan
- Burkina Faso / Burkina Faso
- Ethiopia / Etiyopya
- Egypt / Mısır
- Ivory Coast / Fil Dişi Sahili
- Morocco / Fas
- Poland / Polonya
- The Netherlands / Hollanda
- Russia / Rusya
- Madagascar / Madagaskar
- Niger / Nijer
- Tanzania / Tanzanya
- Mozambique / Mozambik
- Benin
- Palestine / Filistin
- Canada / Kanada
- Lebanon / Lübnan
- Mayotte / Mayotte
- Norway / Norveç
- Panama
- Senegal / Senegal
- Somali
- Iceland / İzlanda





**PROFILES / PROFILLER**

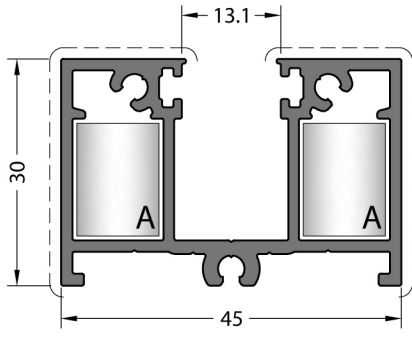

**CODE / KOD**  
**24Z-135-00**

**THEORETICAL WEIGHT kg/m**  
TEORİK AĞIRLIK kg/m  
**0.879**

**CORNER JOINTS**  
KÖŞE BAĞLANTILAR



**A CC-110-11.5**

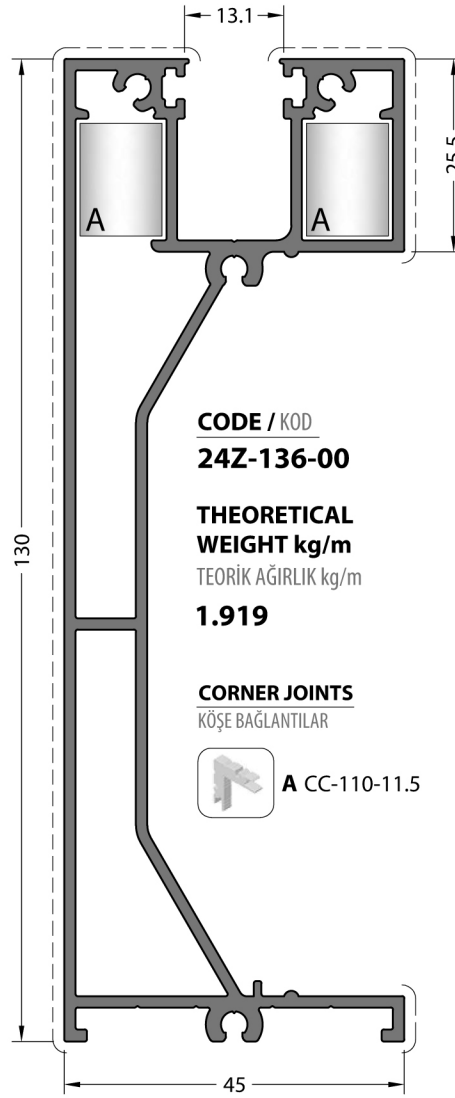

**CODE / KOD**  
**24Z-136-00**

**THEORETICAL WEIGHT kg/m**  
TEORİK AĞIRLIK kg/m  
**1.919**

**CORNER JOINTS**  
KÖŞE BAĞLANTILAR



**A CC-110-11.5**

**CODE / KOD**  
**24Z-137-00**

**THEORETICAL WEIGHT kg/m**  
TEORİK AĞIRLIK kg/m  
**0.602**

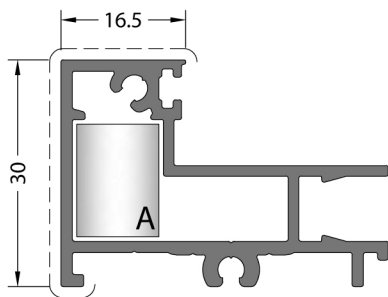
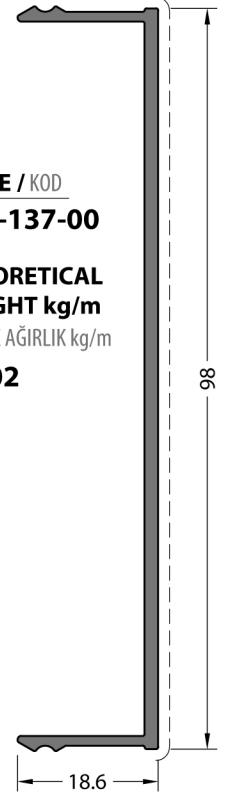

**CODE / KOD**  
**24Z-138-00**

**THEORETICAL WEIGHT kg/m**  
TEORİK AĞIRLIK kg/m  
**0.692**

**CORNER JOINTS**  
KÖŞE BAĞLANTILAR



**A CC-110-11.5**

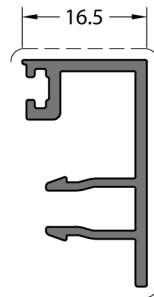

**CODE / KOD**  
**24Z-139-00**

**THEORETICAL WEIGHT kg/m**  
TEORİK AĞIRLIK kg/m  
**0.300**

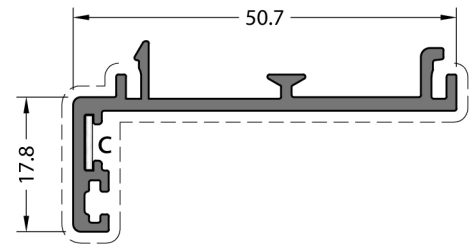

**CODE / KOD**  
**24Z-235-00**

**THEORETICAL WEIGHT kg/m**  
TEORİK AĞIRLIK kg/m  
**0.439**

**CORNER JOINTS**  
KÖŞE BAĞLANTILAR



**C LC-107**

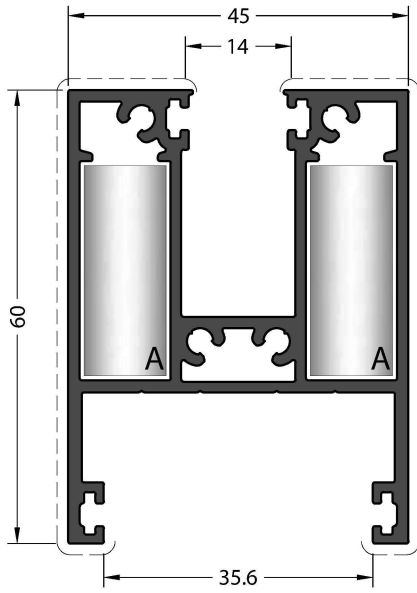

**CODE / KOD**  
**24Z-131-00**

**THEORETICAL WEIGHT kg/m**  
TEORİK AĞIRLIK kg/m  
**1.374**

**CORNER JOINTS**  
KÖŞE BAĞLANTILAR



**A** CC-123-11.5

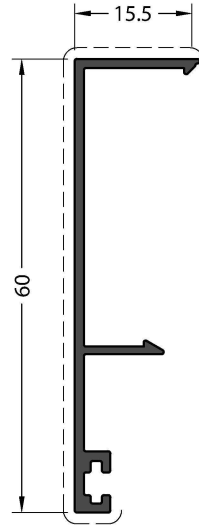

**CODE / KOD**  
**24Z-133-00**

**THEORETICAL WEIGHT kg/m**  
TEORİK AĞIRLIK kg/m  
**0.312**

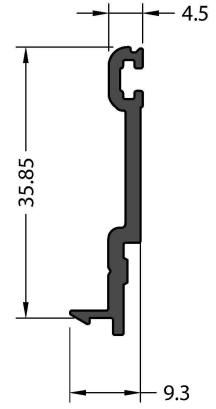

**Mill Finish / Pres**  
**No visible surface. / Görünen yüzeyi yoktur.**

**CODE / KOD**  
**24Z-134-00**

**THEORETICAL WEIGHT kg/m**  
TEORİK AĞIRLIK kg/m  
**0.247**

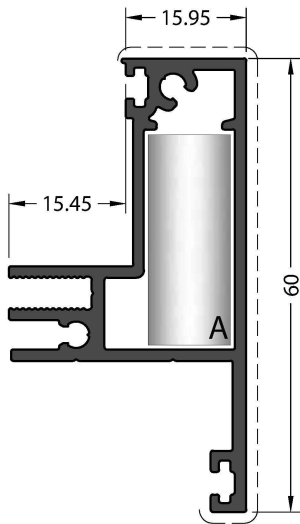

**CODE / KOD**  
**24Z-132-00**

**THEORETICAL WEIGHT kg/m**  
TEORİK AĞIRLIK kg/m  
**0.790**

**CORNER JOINTS**  
KÖŞE BAĞLANTILAR



**A** CC-123-11.5

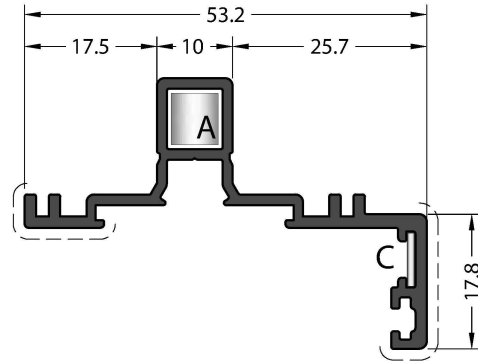

**CODE / KOD**  
**24Z-231-00**

**THEORETICAL WEIGHT kg/m**  
TEORİK AĞIRLIK kg/m  
**0.523**

**CORNER JOINTS**  
KÖŞE BAĞLANTILAR



**A** CC-107-06.9



**C** LC-107

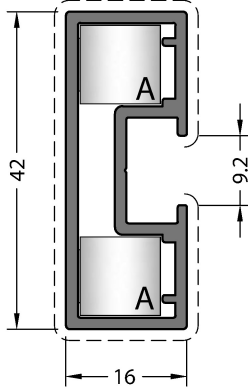

**CODE / KOD**  
**24D-271-00**

**THEORETICAL WEIGHT kg/m**  
TEORİK AĞIRLIK kg/m  
**0.553**

**MECHANICAL CORNER JOINTS**  
MEKANİK KÖŞE BAĞLANTILAR



**A** KC-801-10.5

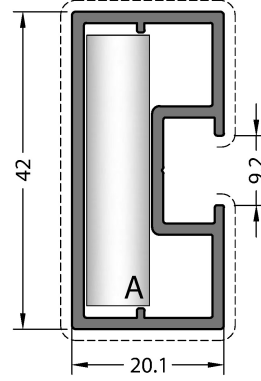

**CODE / KOD**  
**24D-272-00**

**THEORETICAL WEIGHT kg/m**  
TEORİK AĞIRLIK kg/m  
**0.574**

**MECHANICAL CORNER JOINTS**  
MEKANİK KÖŞE BAĞLANTILAR



**A** LC-0936

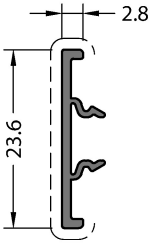

**CODE / KOD**  
**24Z-232-00**

**THEORETICAL WEIGHT kg/m**  
TEORİK AĞIRLIK kg/m  
**0.111**

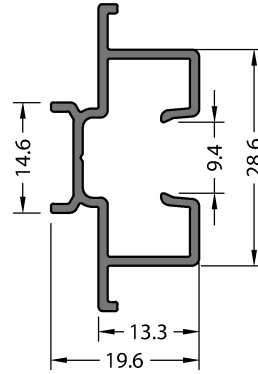

**Mill Finish / Pres**  
**No visible surface.**  
Görünen yüzeyi yoktur.

**CODE / KOD**  
**24Z-233-00**

**THEORETICAL WEIGHT kg/m**  
TEORİK AĞIRLIK kg/m  
**0.332**

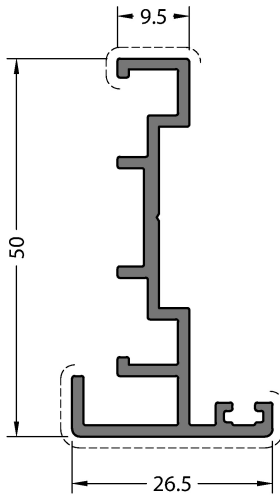

**CODE / KOD**  
**24D-571-00**

**THEORETICAL WEIGHT kg/m**  
TEORİK AĞIRLIK kg/m  
**0.509**

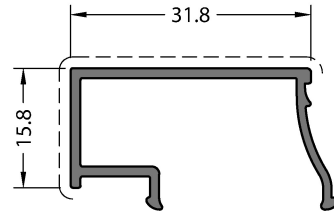

**CODE / KOD**  
**24Z-831-00**

**THEORETICAL WEIGHT kg/m**  
TEORİK AĞIRLIK kg/m  
**0.274**

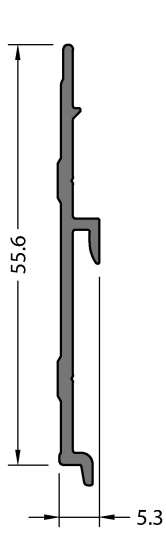

Mill Finish / Pres  
No visible surface.  
Görünen yüzeyi yoktur.

CODE / KOD  
**20-159-00**

THEORETICAL  
WEIGHT kg/m  
TEORİK AĞIRLIK kg/m  
**0.297**

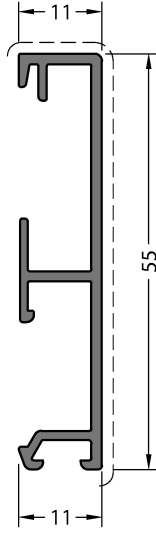

CODE / KOD  
**20-160-00**

THEORETICAL  
WEIGHT kg/m  
TEORİK AĞIRLIK kg/m  
**0.383**

Application Details / Uygulama Detayı

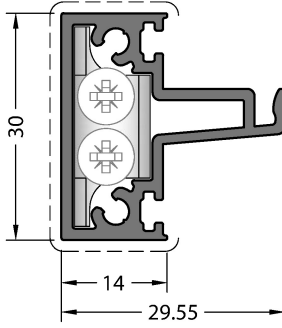
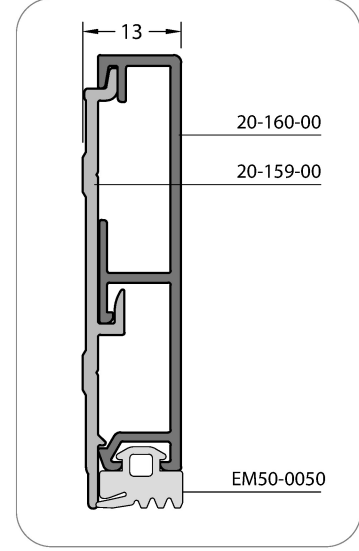

CODE / KOD  
**24Z-301-00**

THEORETICAL  
WEIGHT kg/m  
TEORİK AĞIRLIK kg/m  
**0.528**

CORNER JOINTS  
KÖŞE BAĞLANTILAR



A CA24Z-301-26.4

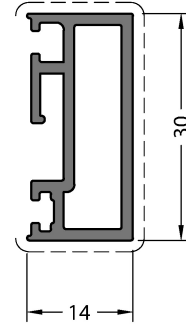

CODE / KOD  
**24Z-302-00**

THEORETICAL  
WEIGHT kg/m  
TEORİK AĞIRLIK kg/m  
**0.388**

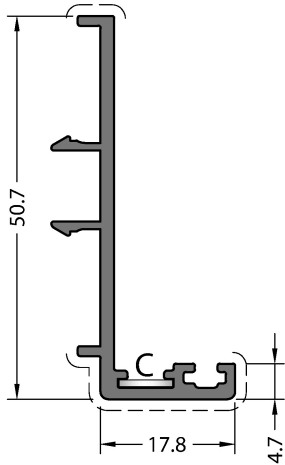

CODE / KOD  
**24Z-236-00**

THEORETICAL  
WEIGHT kg/m  
TEORİK AĞIRLIK kg/m  
**0.416**

CORNER JOINT  
KÖŞE BAĞLANTI



C LC-107

**DETAILS / DETAYLAR**

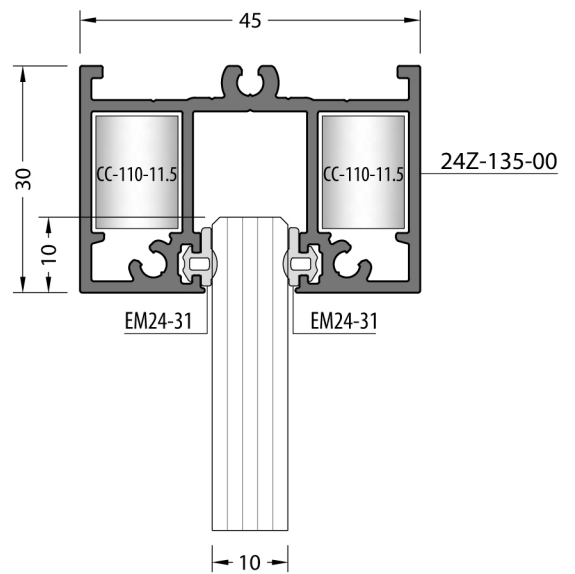
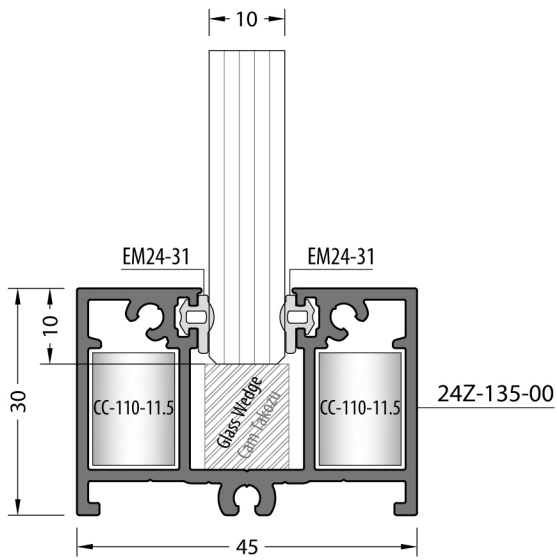
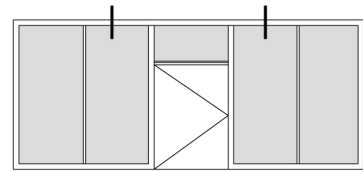
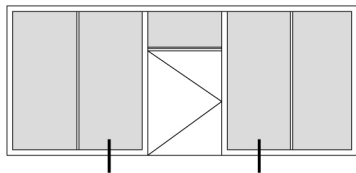
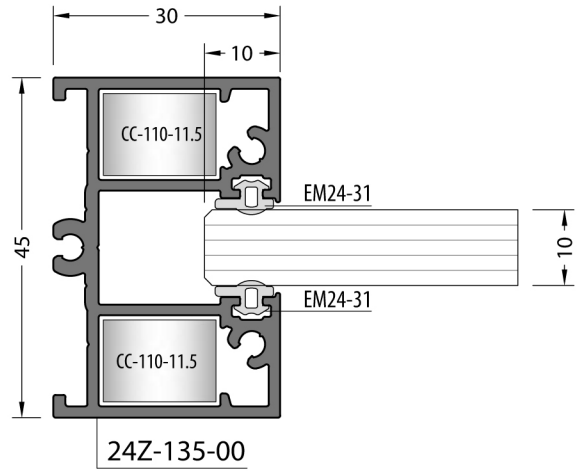
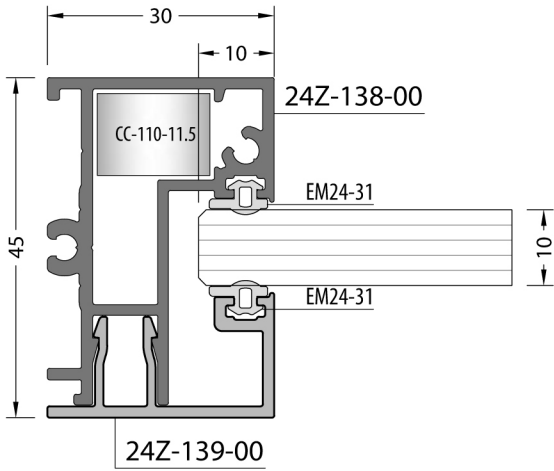
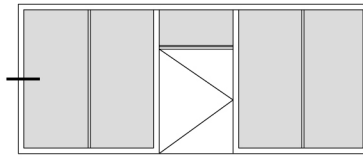

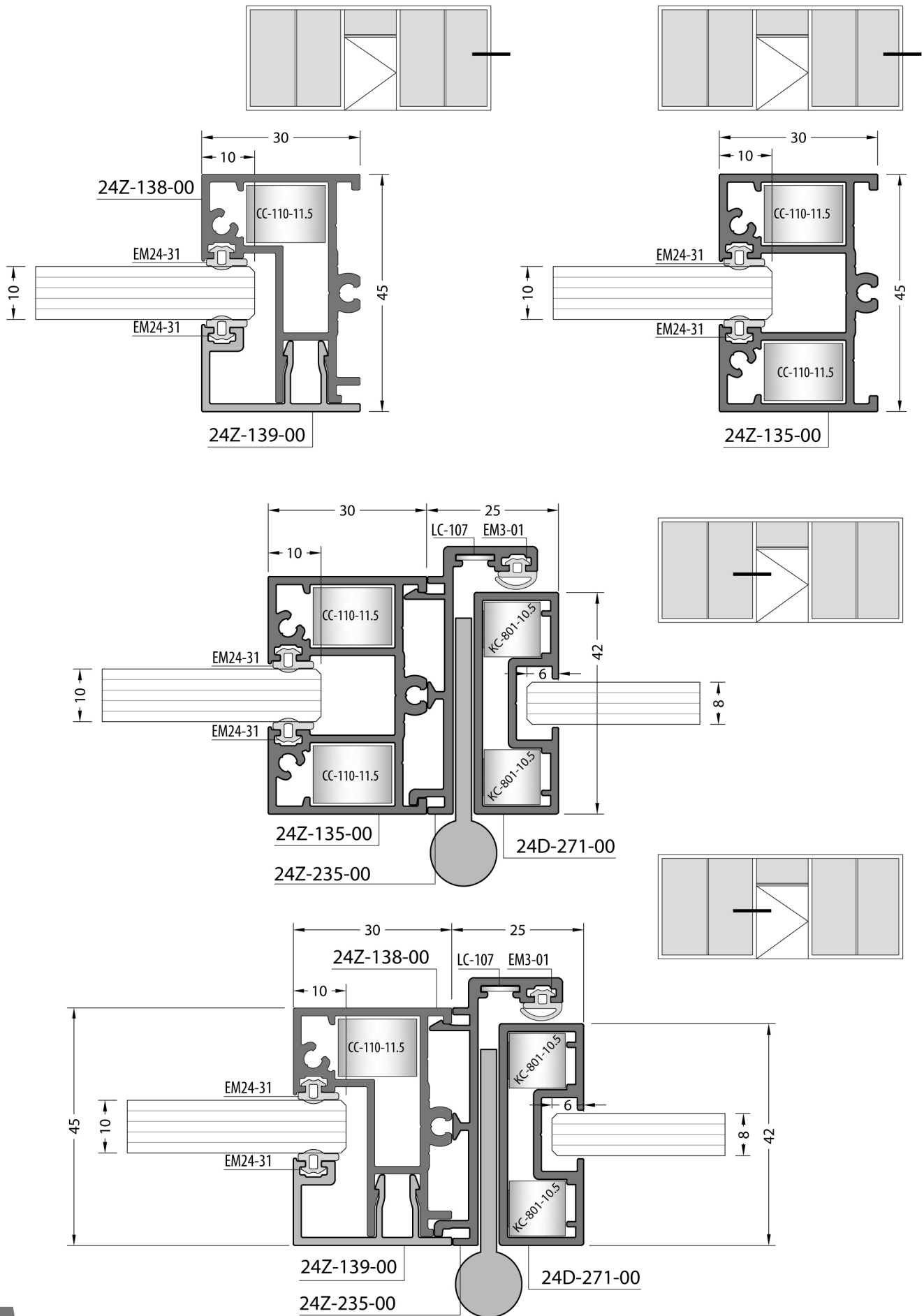

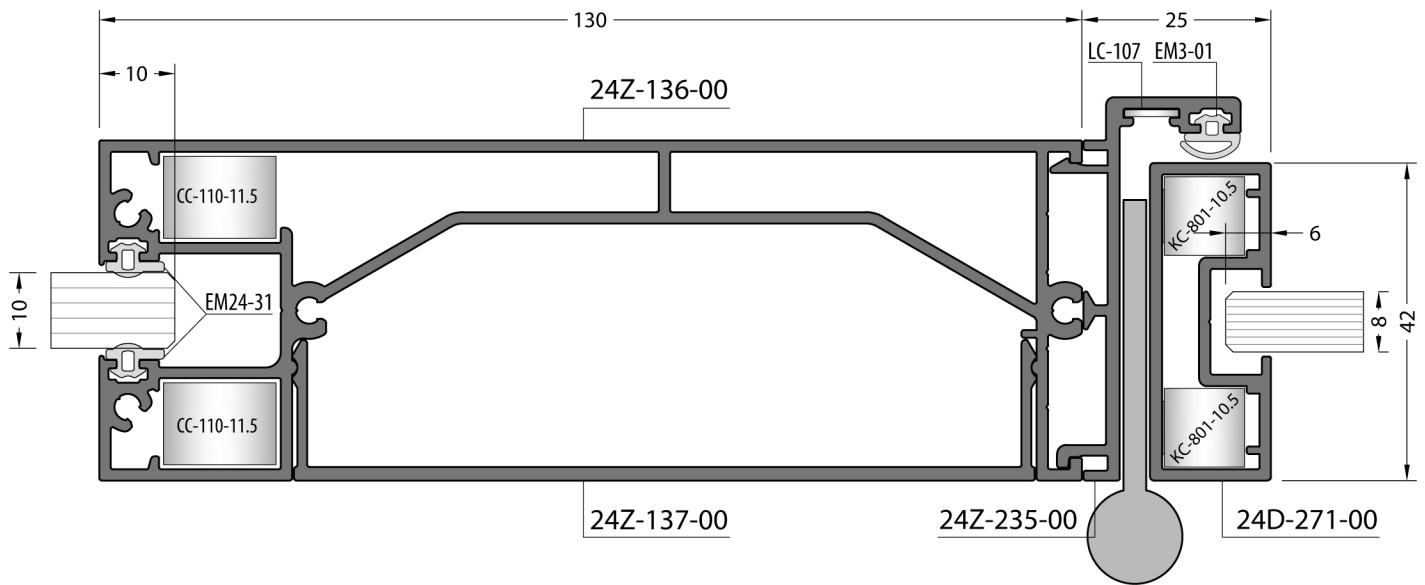
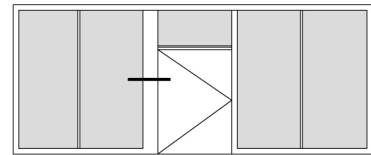
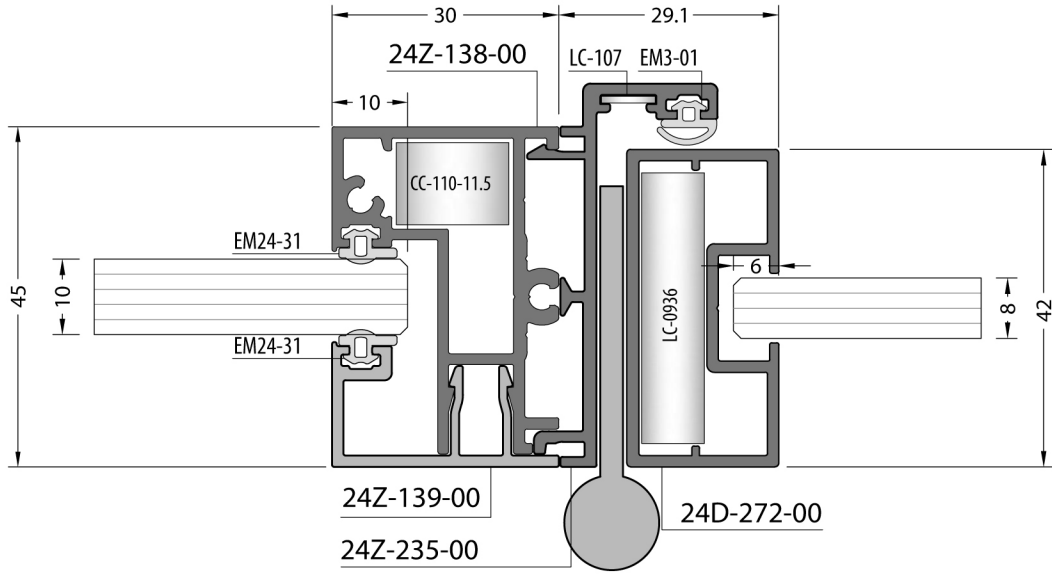
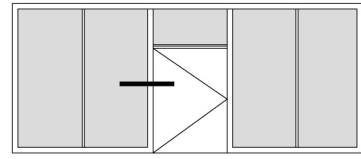

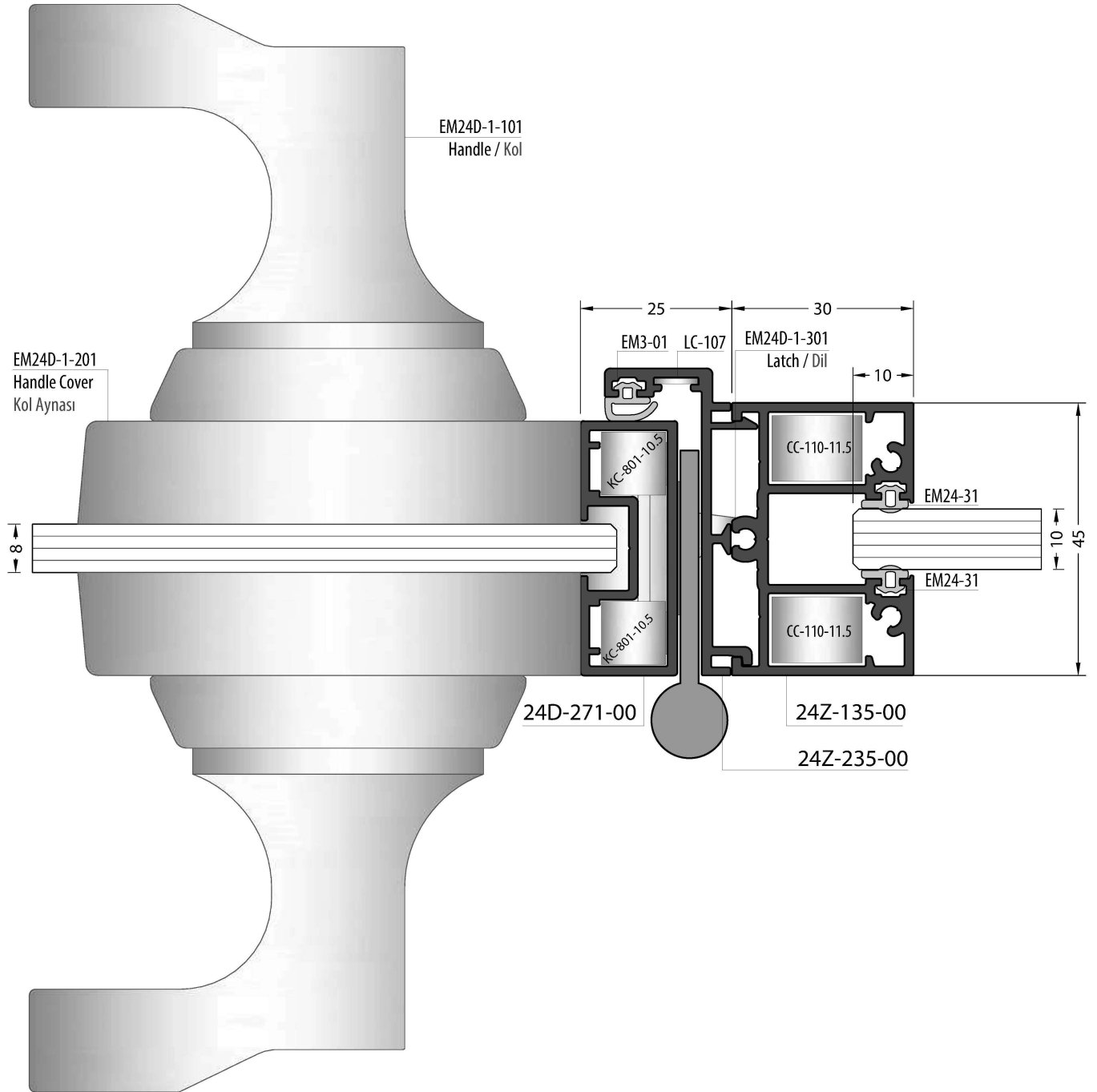
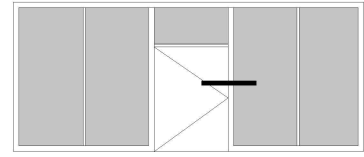

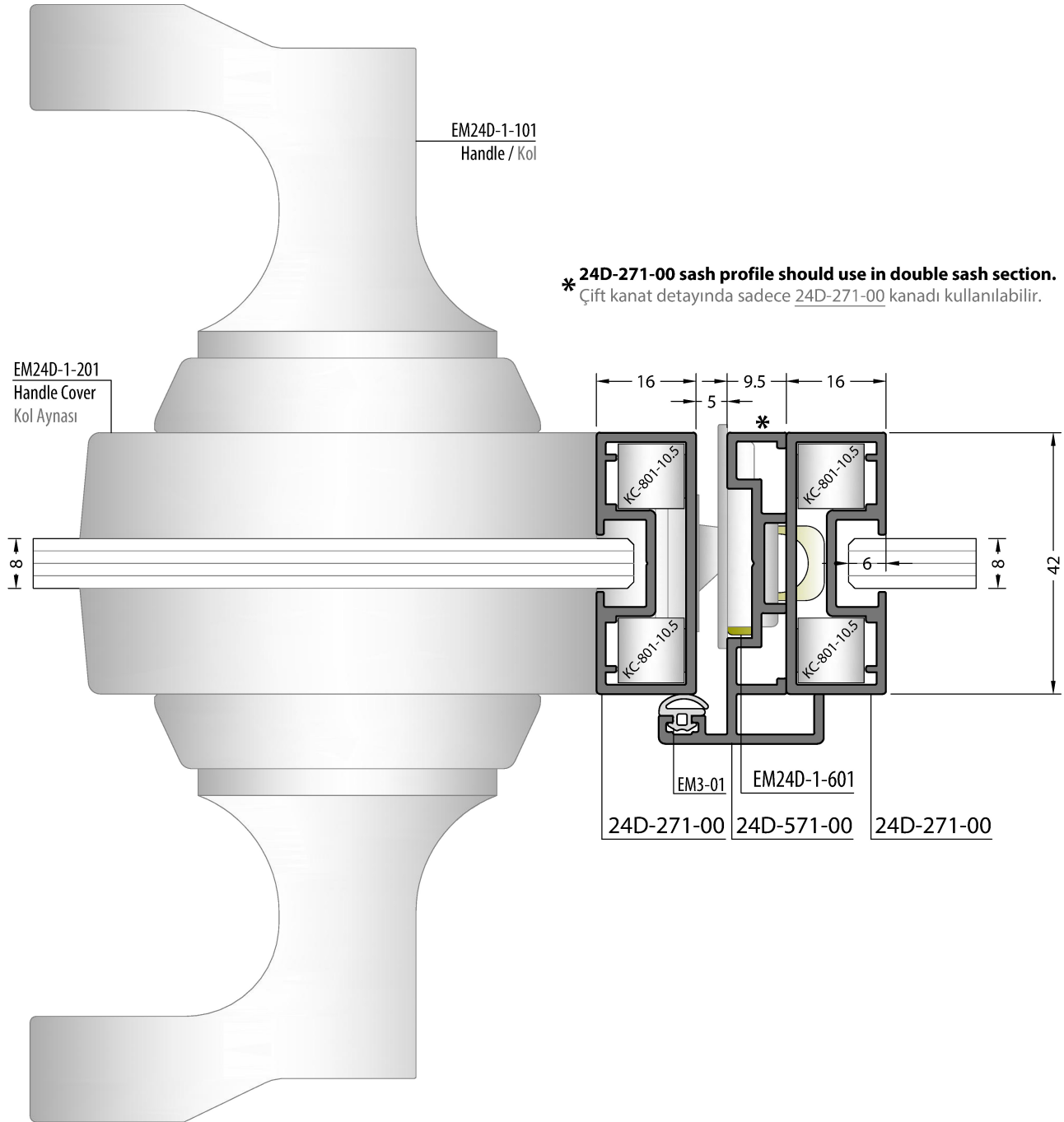
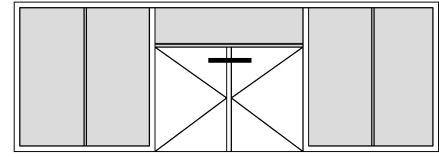

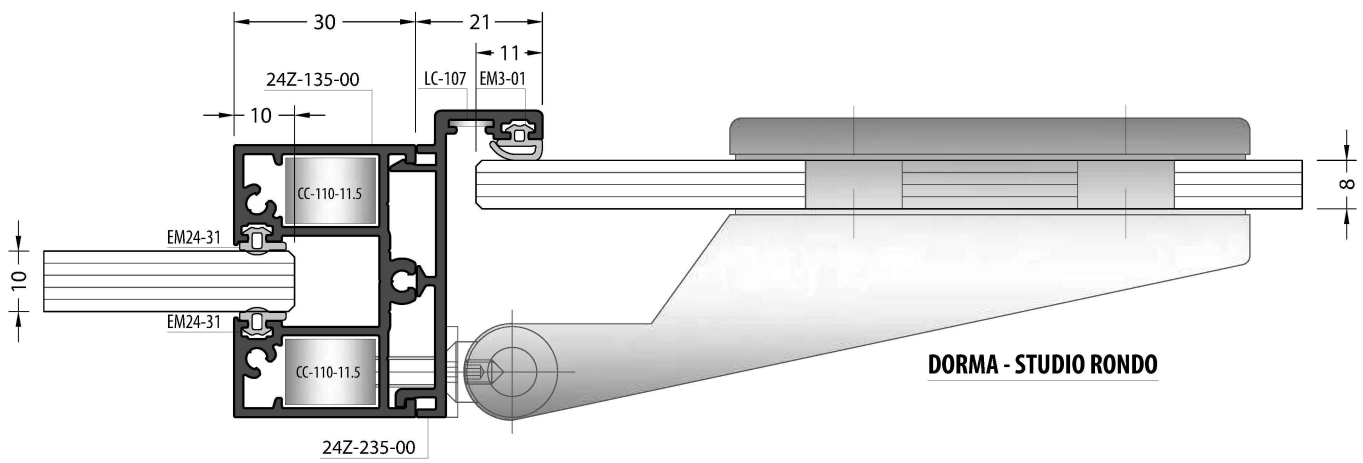
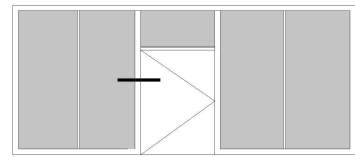
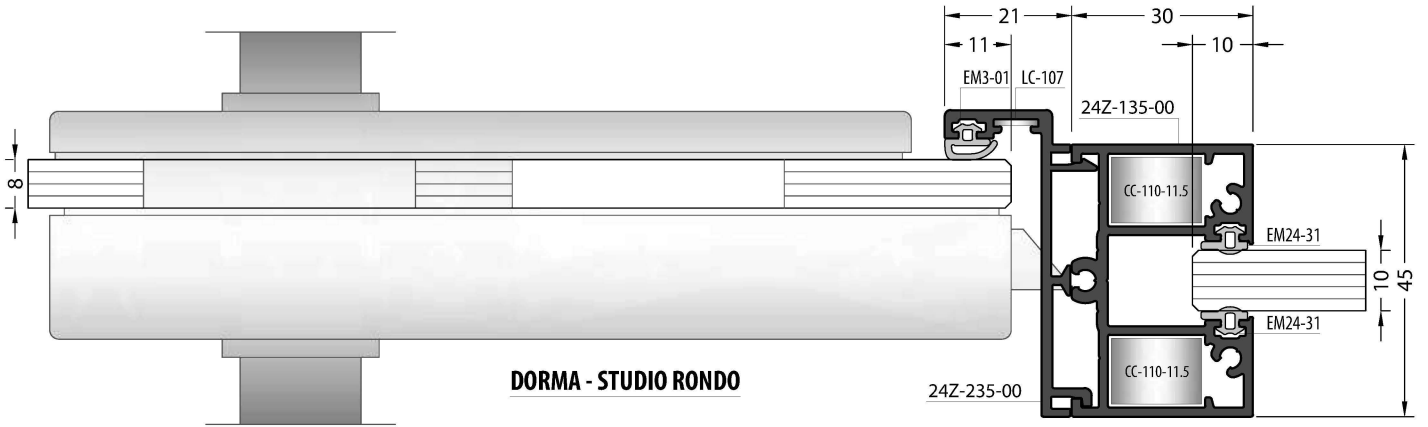
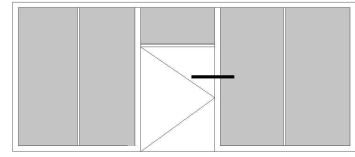

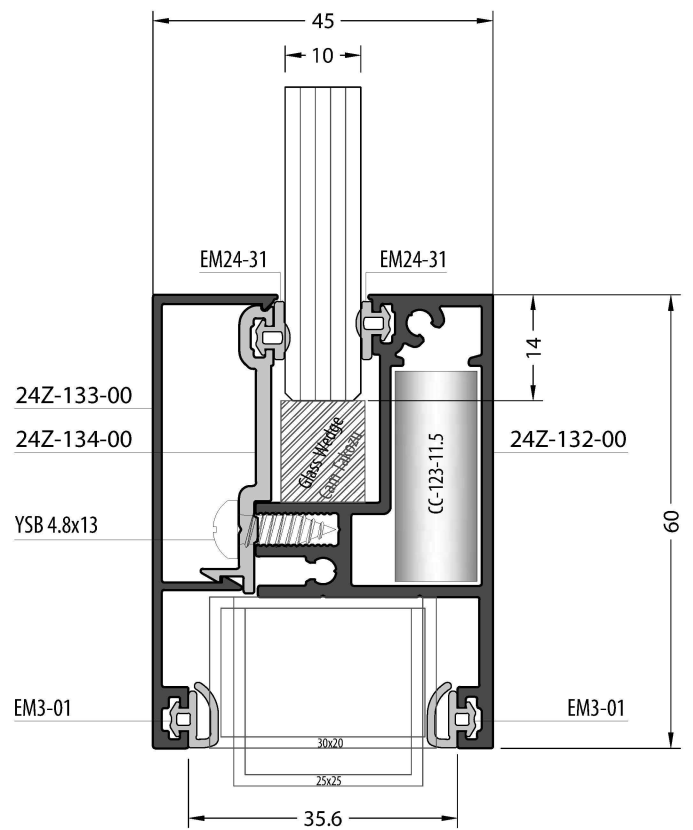
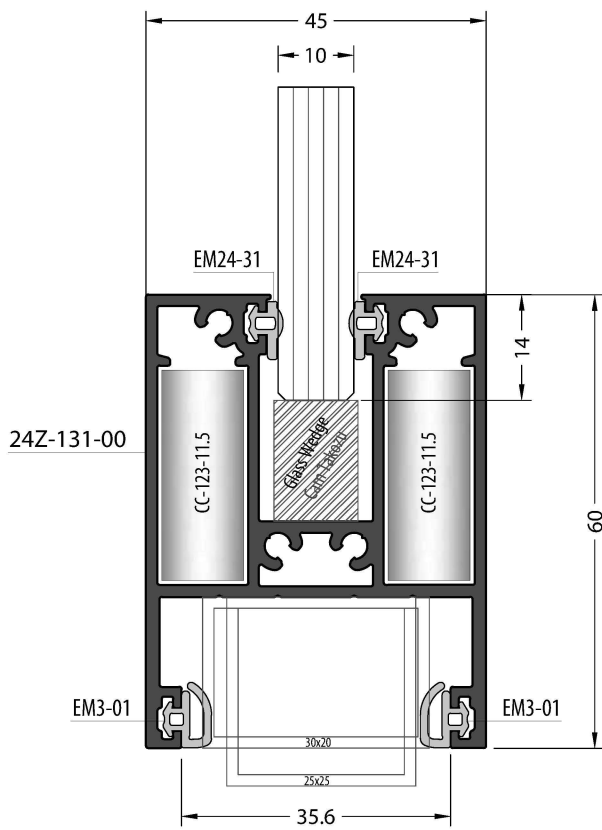
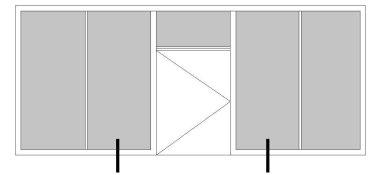
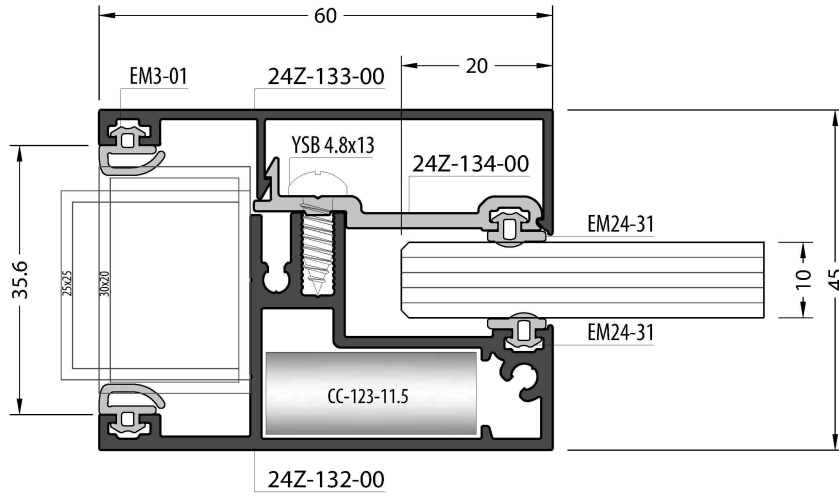
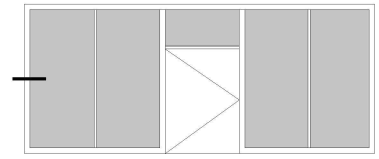

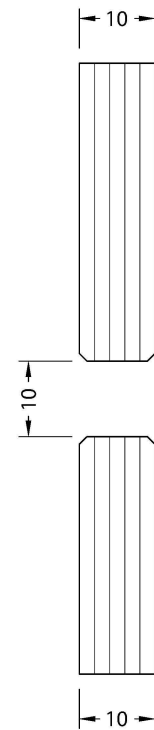
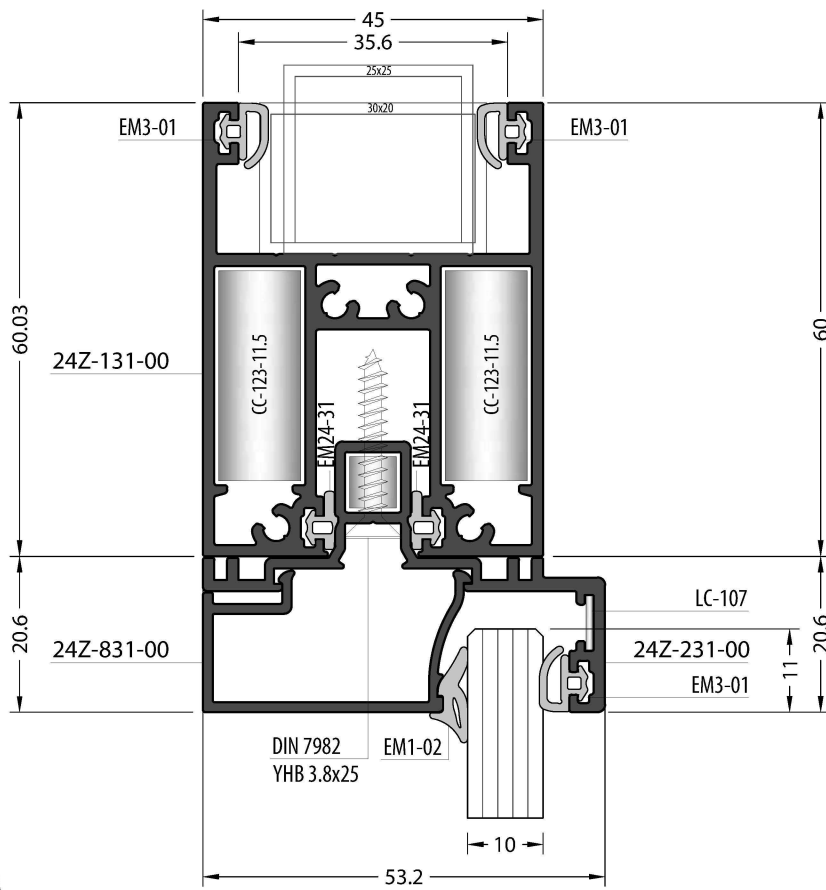
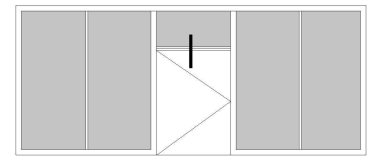
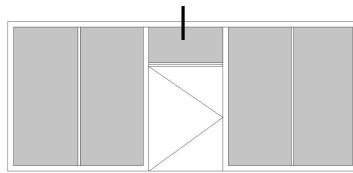
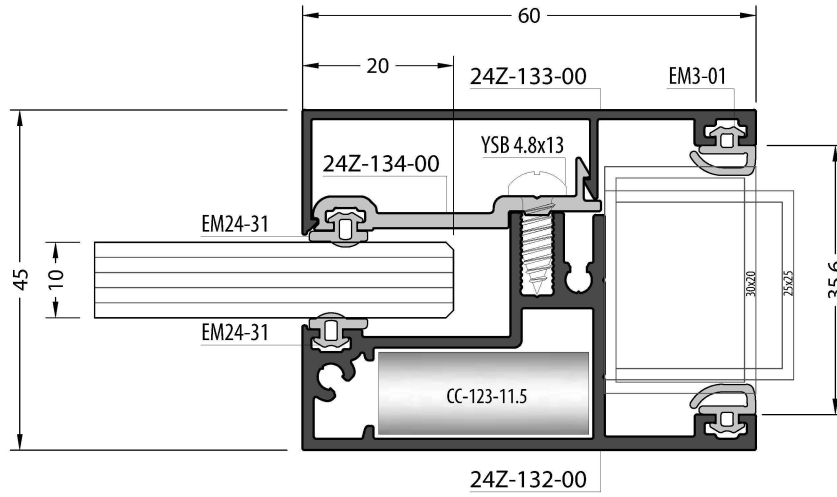
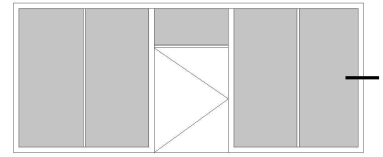

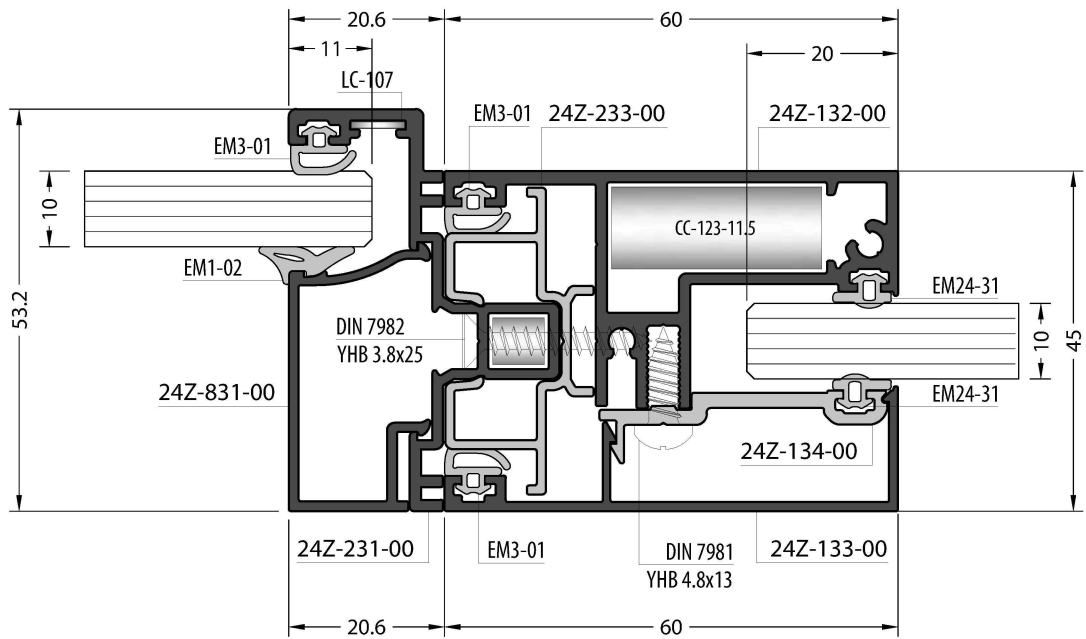
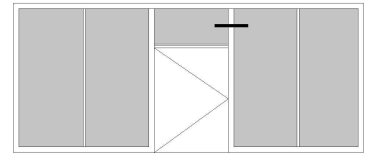
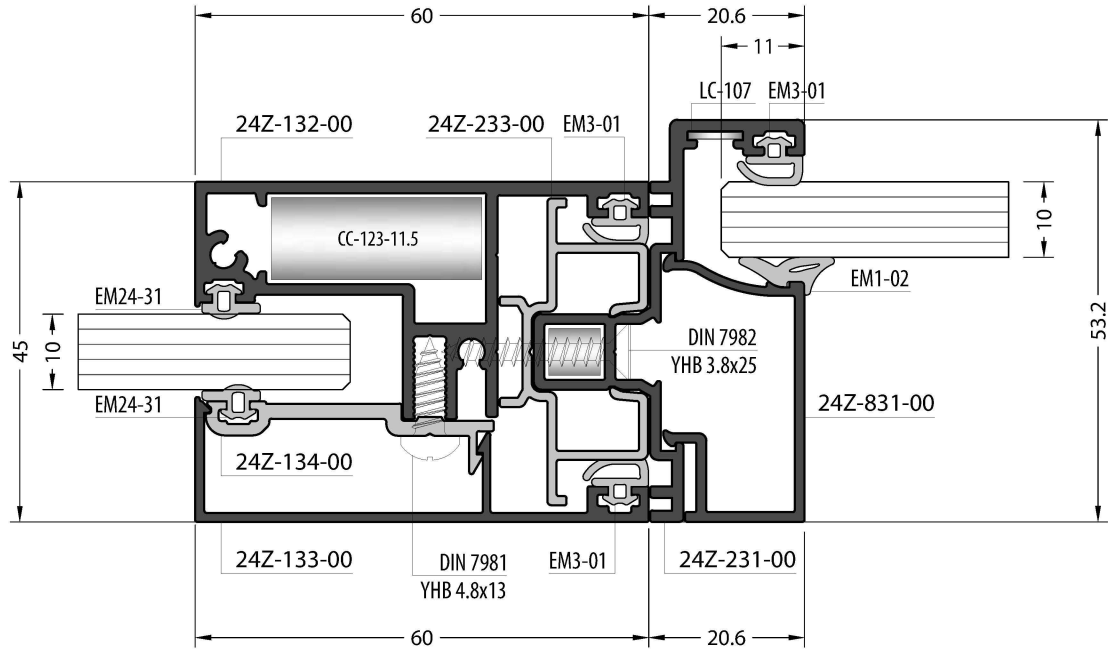
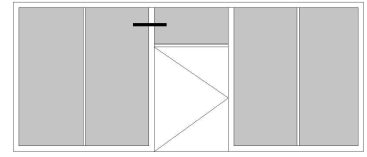

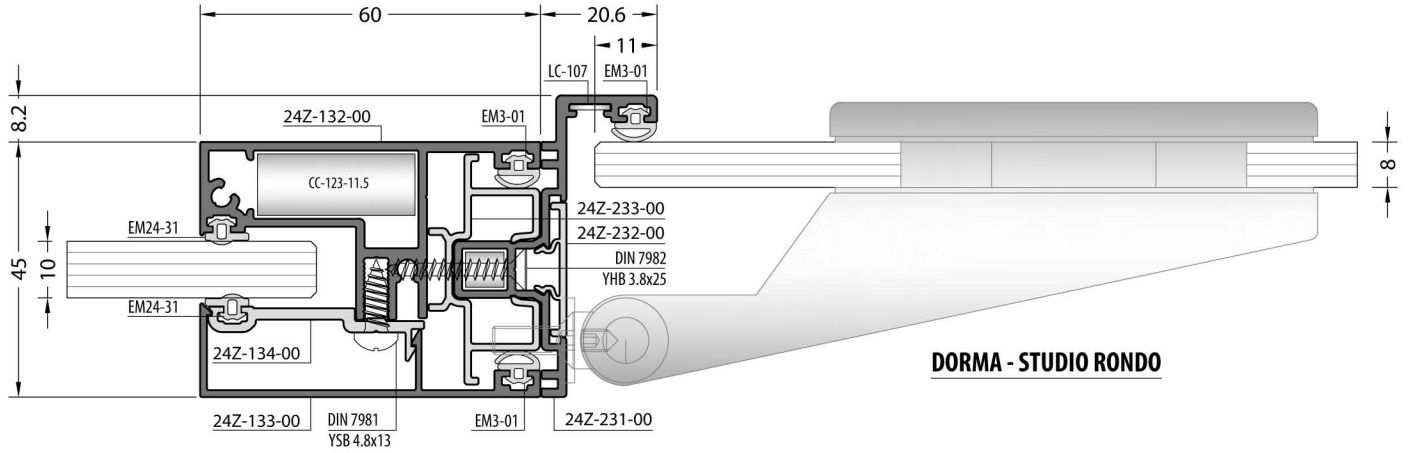
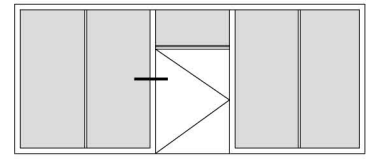

**DORMA - STUDIO RONDO**

No scaled / Ölçeksiz

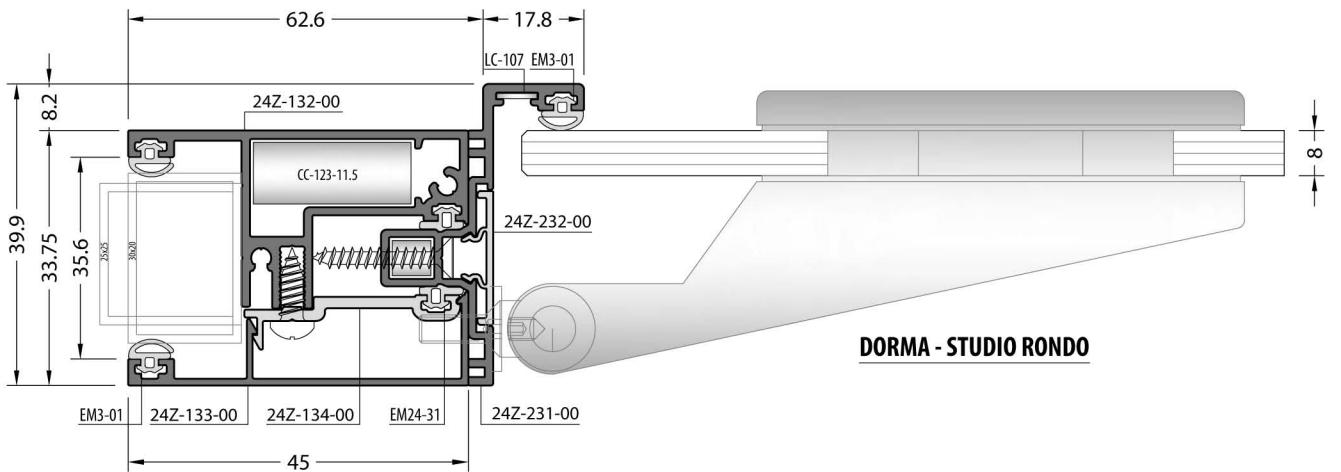
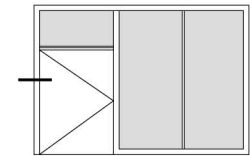

**DORMA - STUDIO RONDO**

No scaled / Ölçeksiz

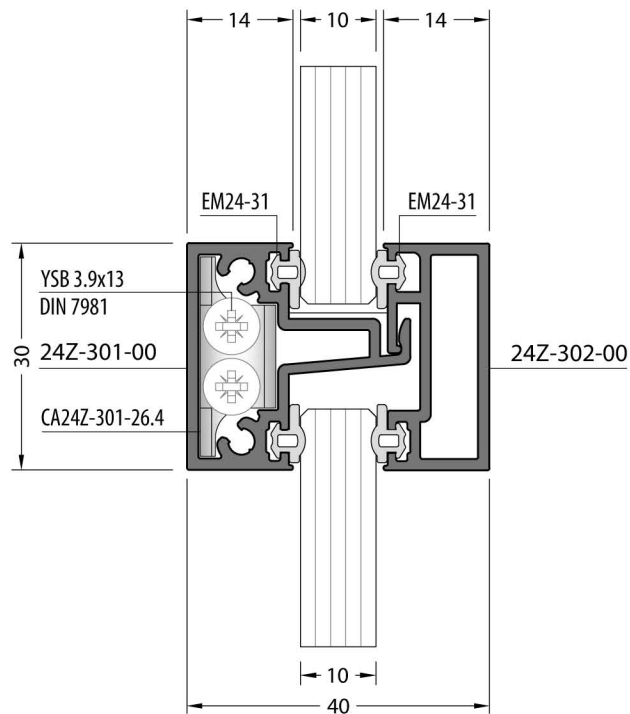
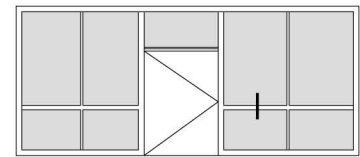
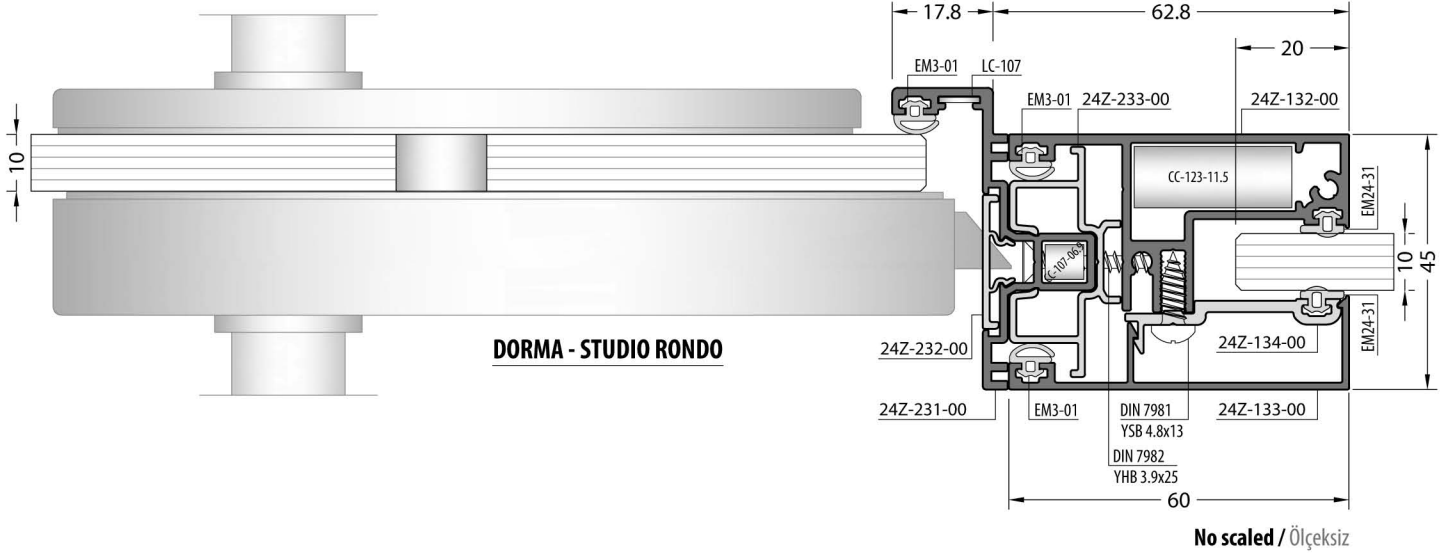
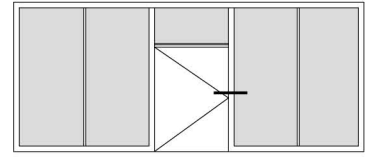

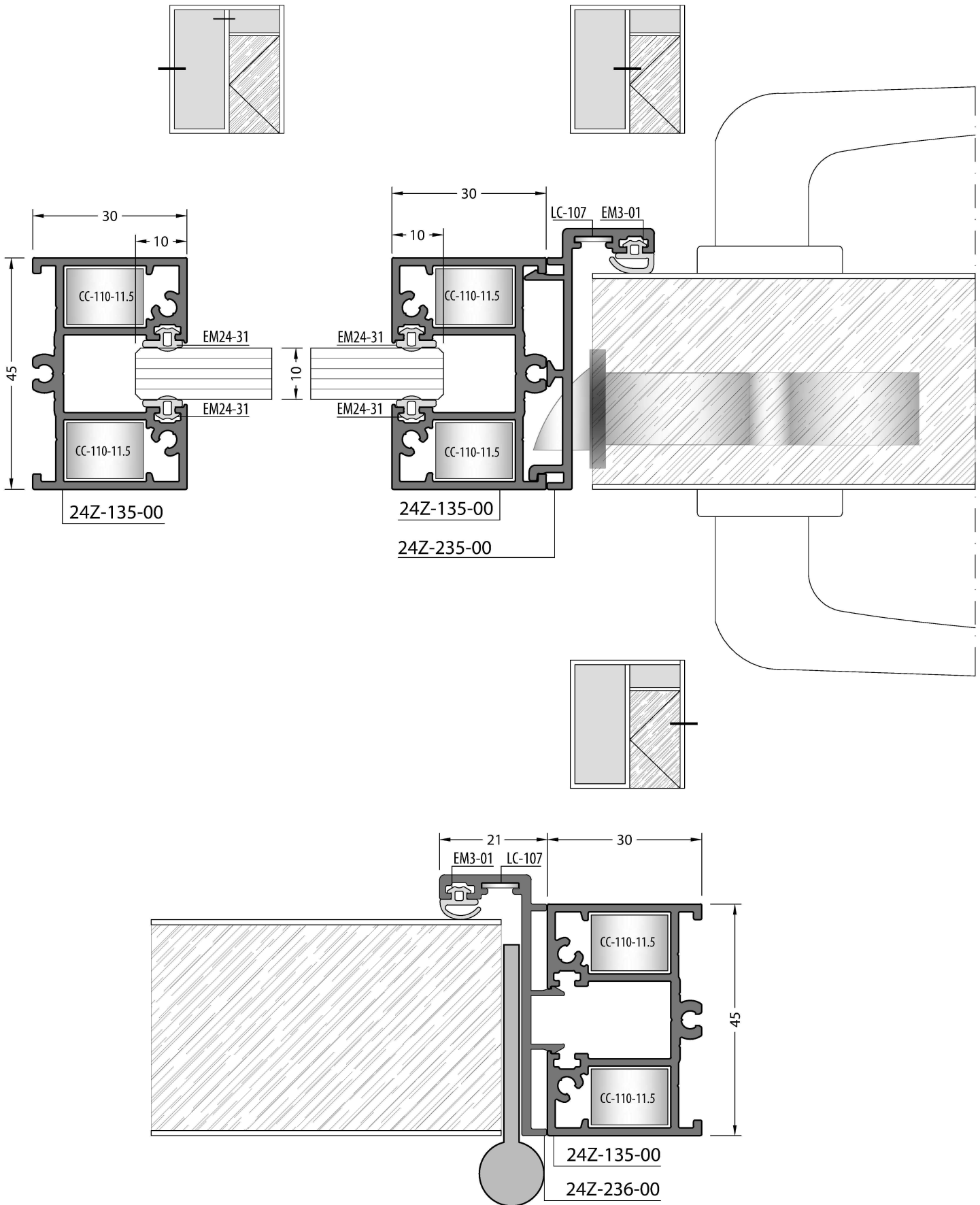

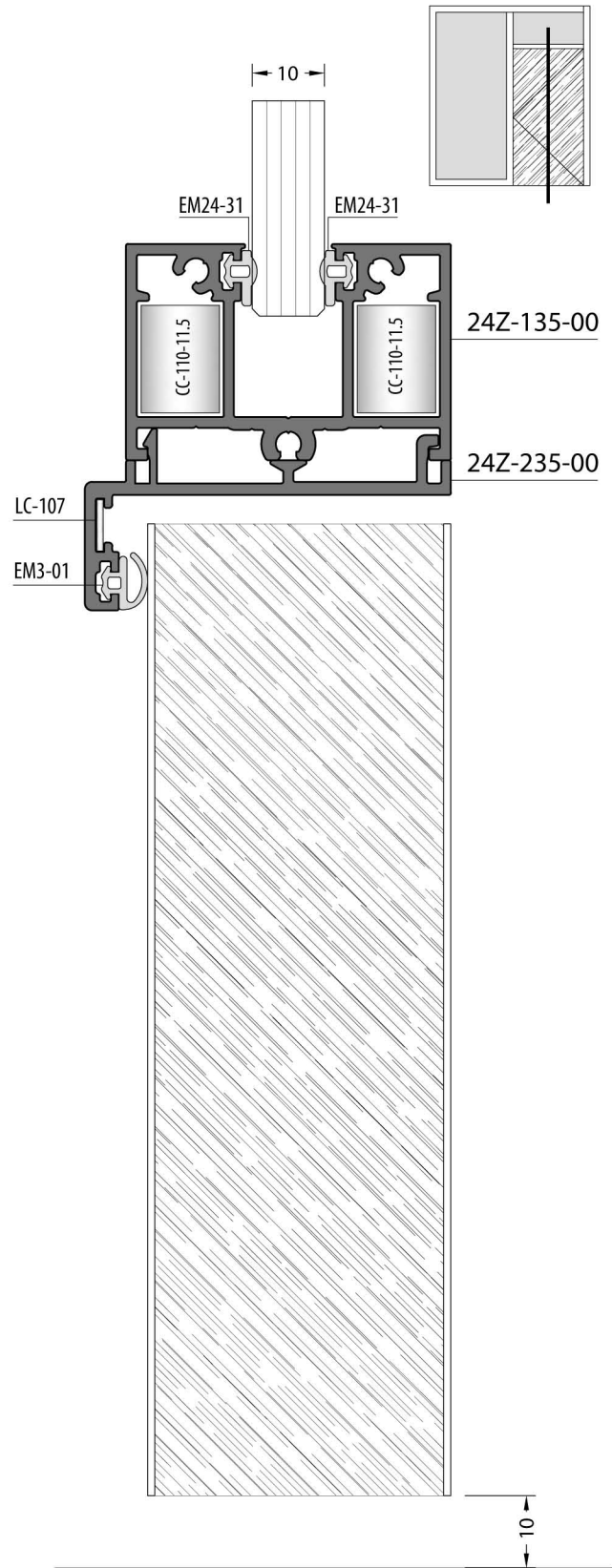
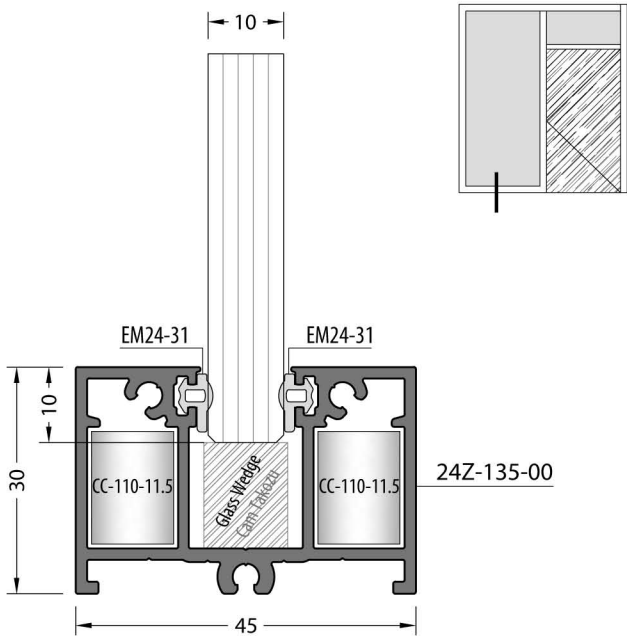
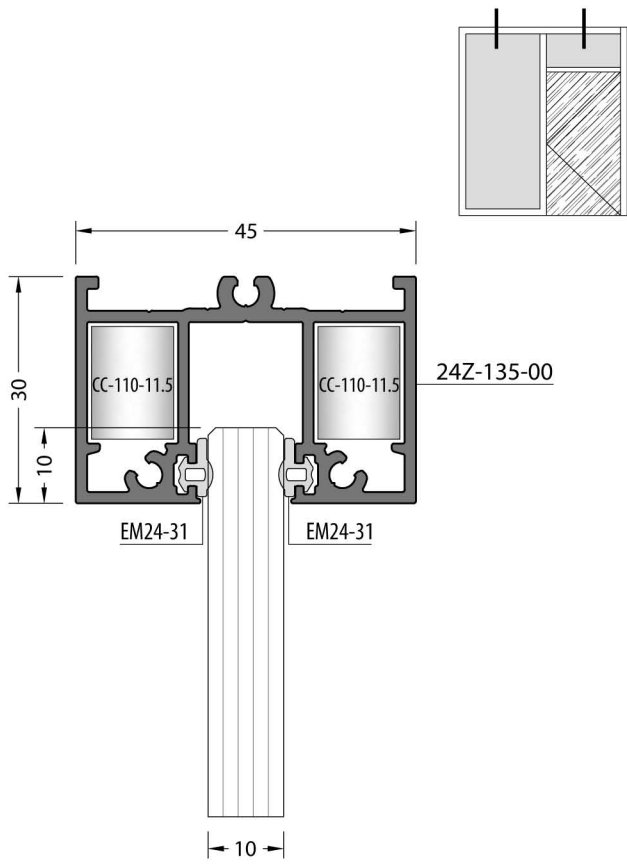

## Separator Profiles / Separatör Profilleri

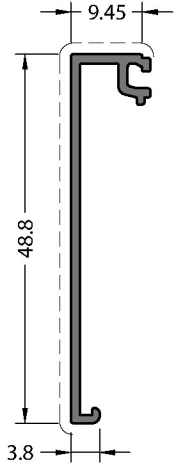

CODE / KOD  
**24Z-142-00**

THEORETICAL  
WEIGHT kg/m  
TEORİK AĞIRLIK kg/m  
**0.225**

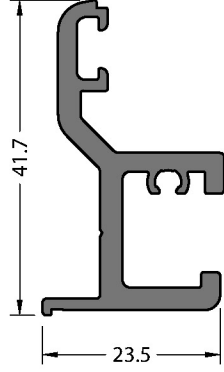

Mill Finish / Pres  
No visible surface. / Görünen yüzeyi yoktur.

CODE / KOD  
**24Z-143-00**

THEORETICAL  
WEIGHT kg/m  
TEORİK AĞIRLIK kg/m  
**0.647**

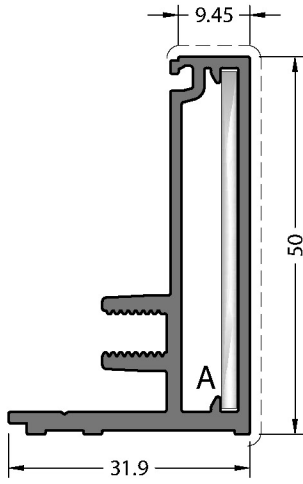

CODE / KOD  
**24Z-141-00**

THEORETICAL  
WEIGHT kg/m  
TEORİK AĞIRLIK kg/m  
**0.769**

CORNER JOINTS  
KÖŞE BAĞLANTILAR



A 14-124-020  
50x50x2 (44.5)

## Details / Detay

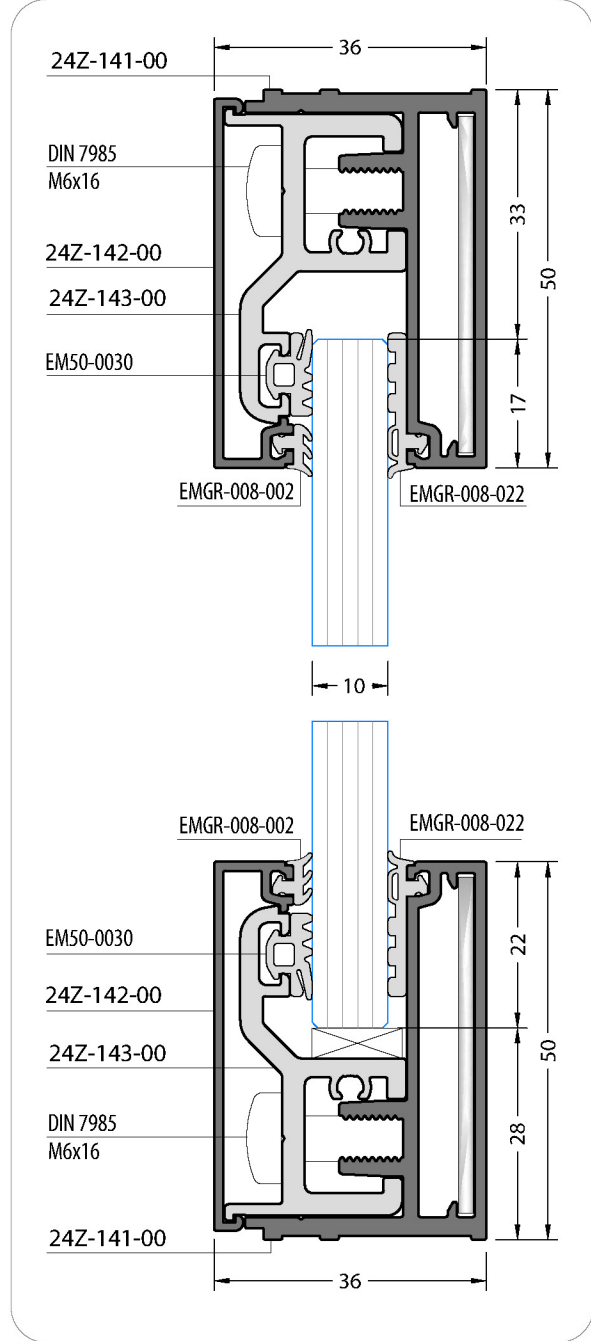









ACCESSORIES / AKSEUARLAR

CORNER JOINTS / KÖŞE BAĞLANTILAR

PACKAGE CODE PAKET KODU	DRAWING ÇİZİM	PROFILE CODE PROFİL KODU	CUTTING SIZE KESİM ÖLÇÜSÜ	APPLICATION PROFILES ÇALIŞTIĞI PROFİLLER
CC-107-06.9		09-107-00	06.9 mm	24Z-231-00
CC-110-11.5		09-110-00	11.5 mm	24Z-135-00
CC-123-11.5		09-123-00	11.5 mm	24Z-131-00 24Z-132-00
KC-801-10.5		09-123-00	11.5 mm	24D-271-00
LC-0936		-	-	24D-272-00
CA24Z-301-26.4		-	26.4 mm	24Z-301-00
LC-107		-	-	24Z-231-00
50x50x2 (44.5)		14-124-020	44.5 mm	24Z-141-00

GASKETS / FİTİLLER

CODE KOD	DRAWING ÇİZİM	DESCRIPTION AÇIKLAMA	MATERIAL MALZEME	WEIGHT AĞIRLIK kg/m	IN ONE PACKAGE PAKET MİKTARI
EM24-31		SASH GASKET KANAT FİTİLİ	EPDM	0.015	625 m
EM3-01		ACOUSTICAL GASKET BİNİ FİTİLİ	EPDM	0.032	400 m
EM1-02		INSIDE GLASS GASKET İÇ CAM FİTİLİ	EPDM	0.040	375 m
EM20-160		KICK PLATE GASKET EŞİK FİTİLİ	EPDM	0.026	150 m
EM50-0030		GLASS GASKET CAM FİTİLİ	EPDM	0.050	300 m
EMGR-008-022		GLASS GASKET CAM FİTİLİ	EPDM	0.056	250 m
EMGR-008-002		GLASS GASKET CAM FİTİLİ	EPDM	0.022	625 m

ACCESSORIES / AKSEUARLAR

CODE / KOD	VIEW RESİM	DESCRIPTION AÇIKLAMA	QUANTITY MİKTAR
EM24D-1-101		HANDLE KOL	1 Pieces / Adet
EM24D-1-201		HANDLE COVER KOL AYNASI	1 Pieces / Adet
EM24D-1-301		HANDLE DİL	1 Pieces / Adet
EM24D-1-401		STRIKER KARŞILIK	1 Pieces / Adet
EM24D-1-501		HINGE MENTEŞE	1 Pieces / Adet
EM24D-1-601		DOOR LATCH KAPI SÜRGÜSÜ	1 Pieces / Adet

ACCESSORIES / AKSEUARLAR

PACKAGE CODE PAKET KODU	DRAWING ÇİZİM	APPLICATION PROFILES ÇALIŞTIĞI PROFİLLER	DESCRIPTION AÇIKLAMA	MATERIAL MALZEME
EM24Z-141		24Z-141-00	CAP / KAPAK	ALUMINIUM ALÜMİNYUM

**MECHANICAL CORNER JOINT DRILING DIMENSIONS**

MEKANİK BAĞLANTI DELİK ÖLÇÜLERİ

**24D-271-00**

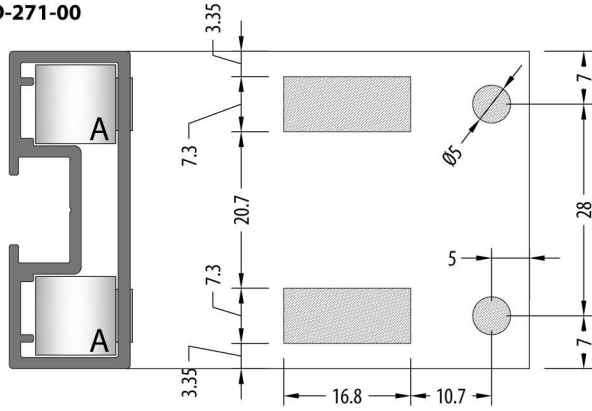

**KC-801-10.5**

**24D Manuel Punch Machine**  
24D Manuel Punch Makinası



**GLASS DOOR - GLASS DRILING DIMENSIONS**

CAM KAPI - CAM DELME ÖLÇÜLERİ

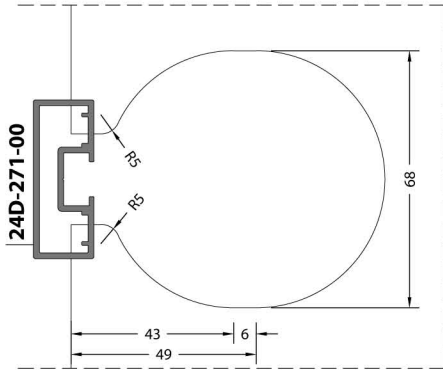

**GLASS DOOR - HANDLE COVER PLATE DIMENSIONS**

CAM KAPI - KOL AYNASI ÖLÇÜLERİ

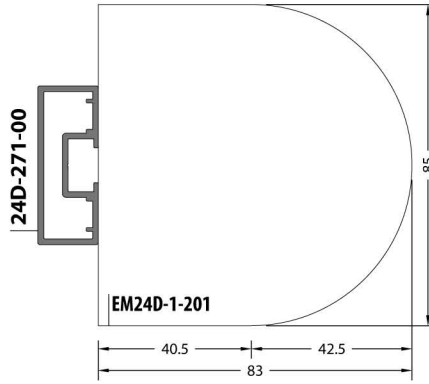

**GLASS DOOR - LATCH DRILING DIMENSIONS**

CAM KAPI - DİL FREZELEME ÖLÇÜLERİ

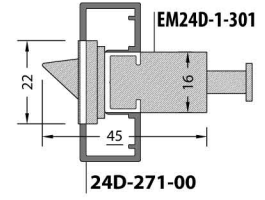

**24D-271-00**

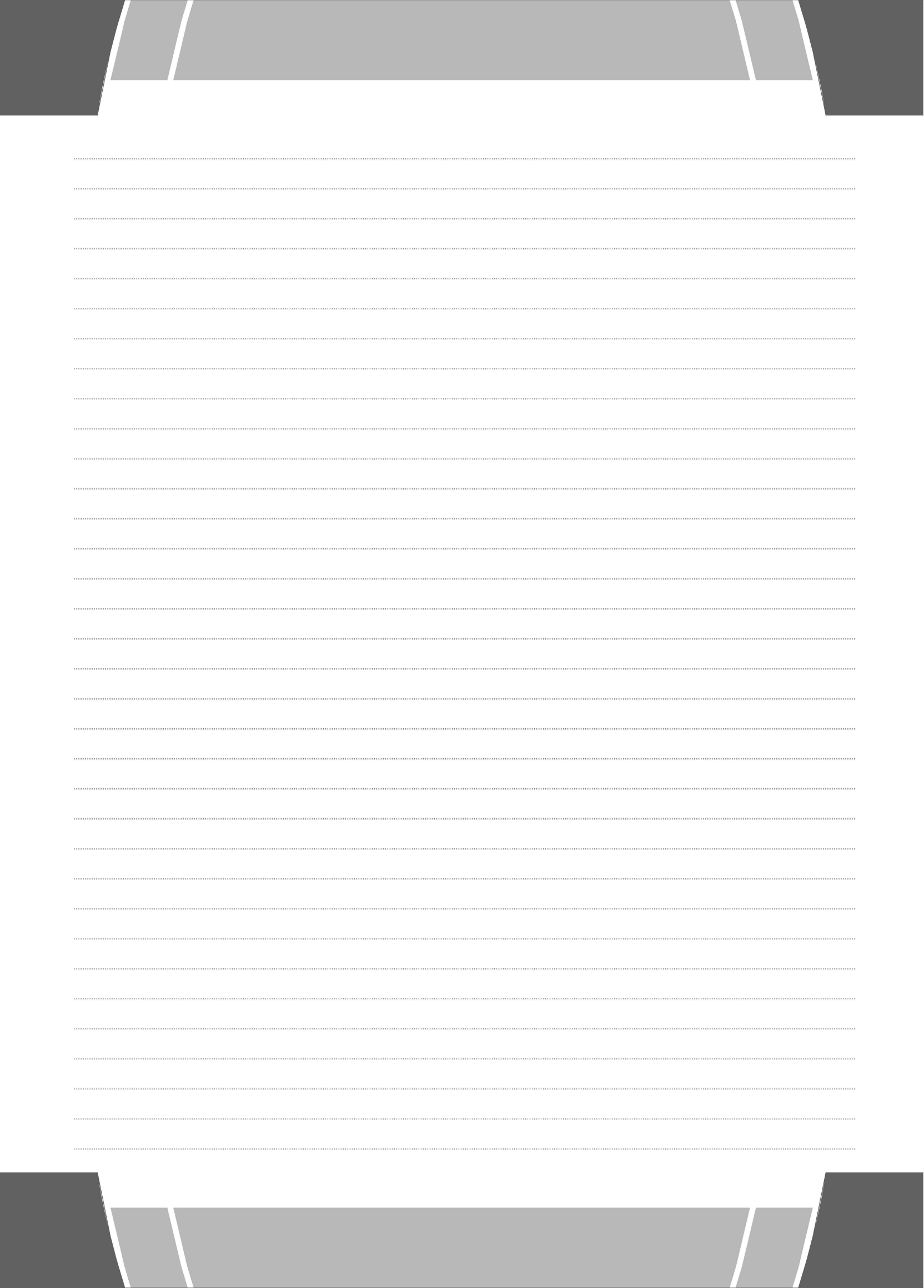

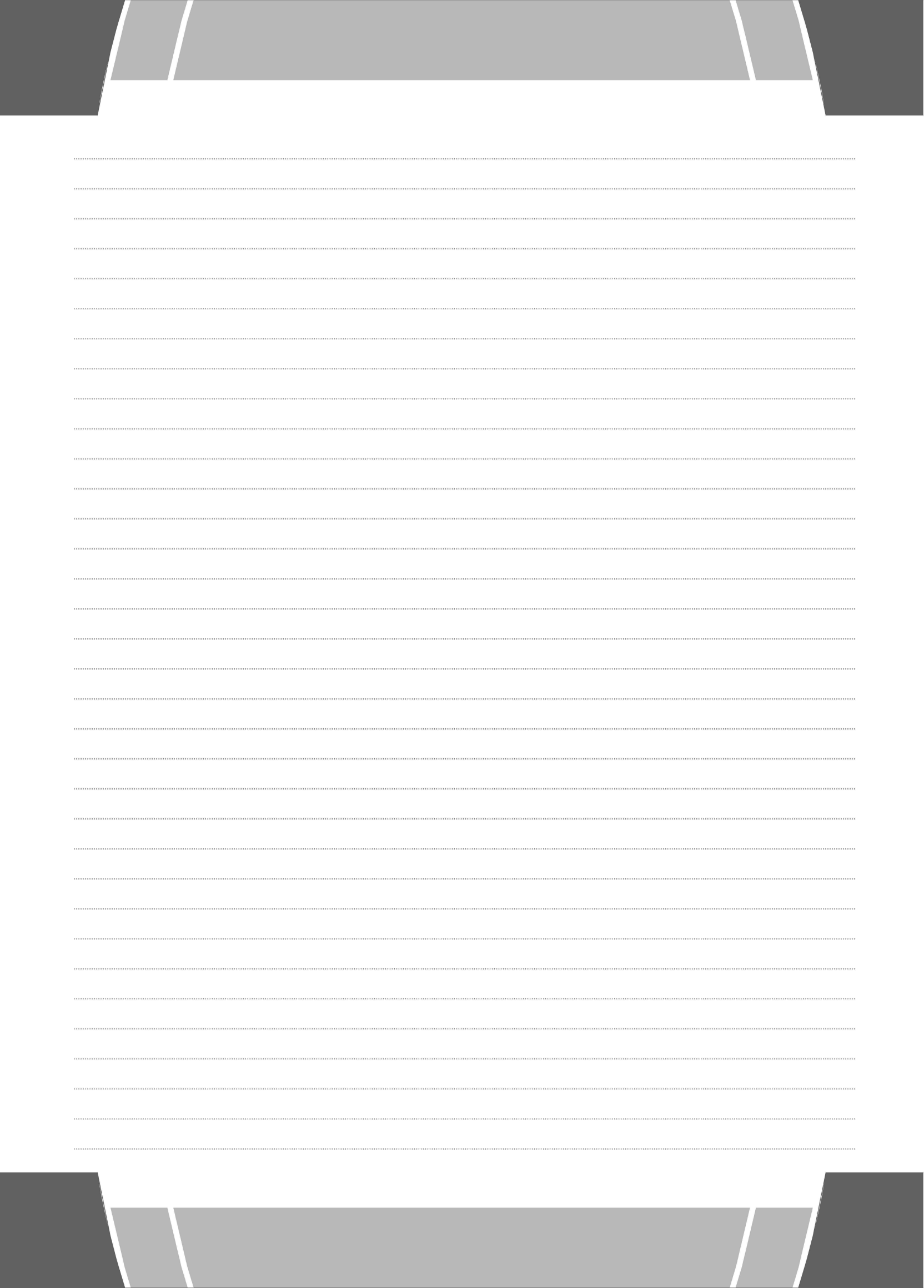



**KURTOĞLU BAKIR KURŞUN SANAYİ A.Ş.**

Velimeşe Organize Sanayi Bölgesi Akbayır Yolu  
Küme Evler No: 81 Ergene 59851 Tekirdağ / Türkiye  
T: 0 282 684 70 00 F: 0 282 684 70 01  
[www.kurtogluas.com](http://www.kurtogluas.com)